



UNIVERSITY OF CAMBRIDGE INTERNATIONAL EXAMINATIONS
General Certificate of Education Ordinary Level

CANDIDATE
NAME

CENTRE
NUMBER

--	--	--	--	--

CANDIDATE
NUMBER

--	--	--	--

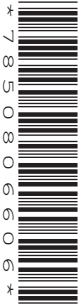

FISHERIES SCIENCE

5151/01

Paper 1

October/November 2009

1 hour 30 minutes

Candidates answer on the Question Paper

No Additional Materials are required.

READ THESE INSTRUCTIONS FIRST

Write your Centre number, candidate number and name on all the work you hand in.

Write in dark blue or black pen.

You may use a pencil for any diagrams, graphs or rough working.

Do not use staples, paper clips, highlighters, glue or correction fluid.

DO NOT WRITE ON ANY BARCODES.

Answer **all** questions.

At the end of the examination, fasten all your work securely together.

The number of marks is given in brackets [] at the end of each question or part question.

For Examiner's Use	
1	
2	
3	
4	
5	
6	
7	
8	
9	
10	
Total	

This document consists of **15** printed pages and **1** blank page.



1 (a) Fig. 1.1 shows the structure of the Earth.

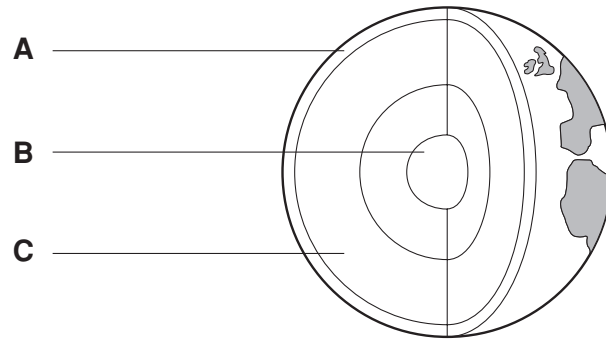

Fig. 1.1

Name the layers labelled **A**, **B** and **C**.

A

B

C [3]

(b) (i) Fig. 1.2 shows three types of reef.

Name each type of reef using names from the list below.

atoll reef barrier reef fringing reef

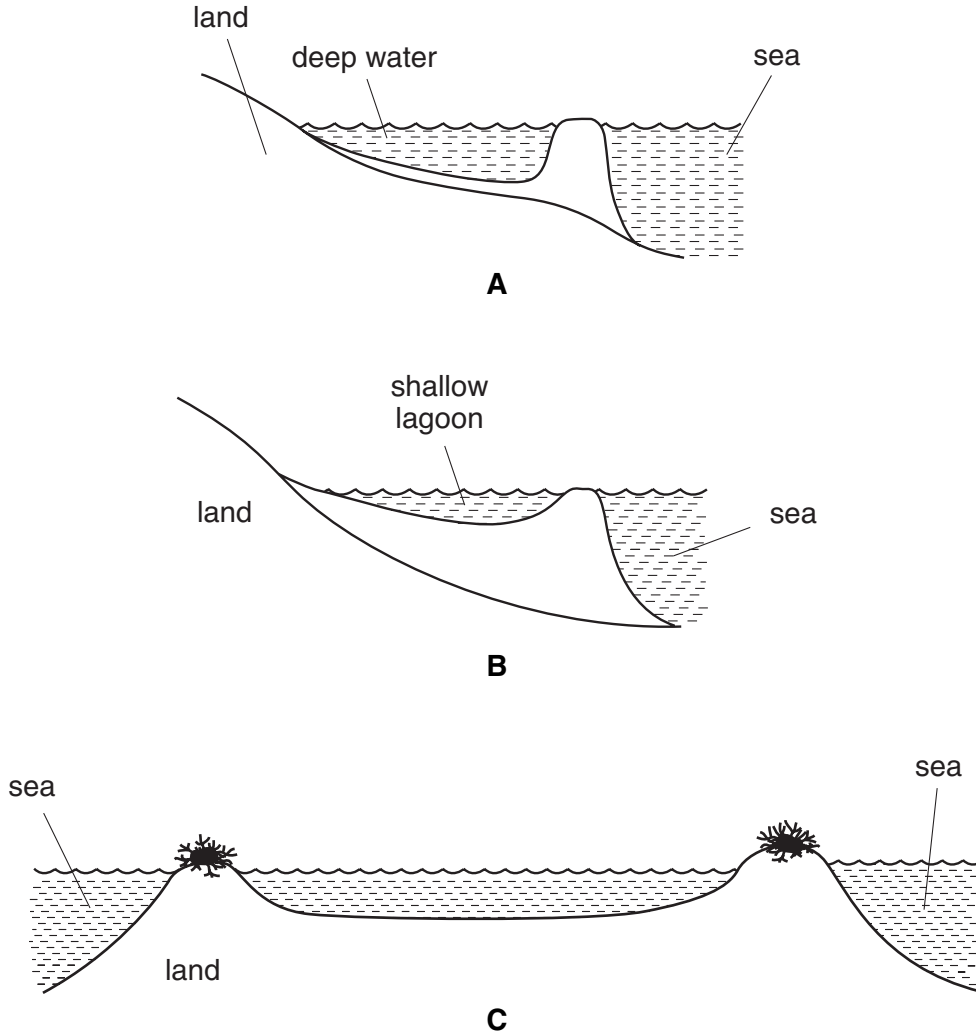

Fig. 1.2

A.....
B.....
C.....[3]

(ii) Name **two** organisms that help to produce reefs.

1
 2[2]

For
Examiner's
Use

2 (a) Fig. 2.1 shows a food pyramid.

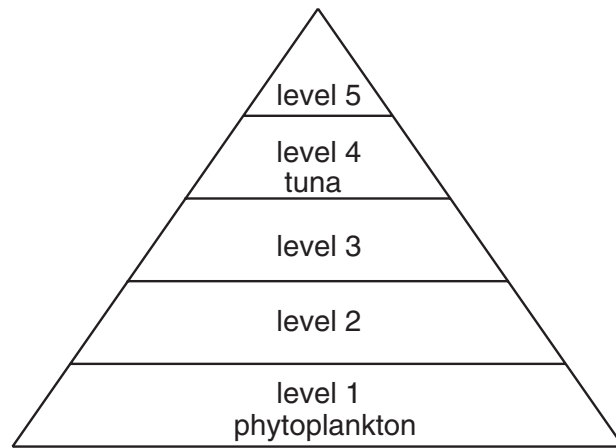

Fig. 2.1

State the level at which the following organisms would be found.

(i) Humans[1]

(ii) Bait fish[1]

(b) Fig. 2.2 shows how the percentage of light passing through seawater changes with depth.

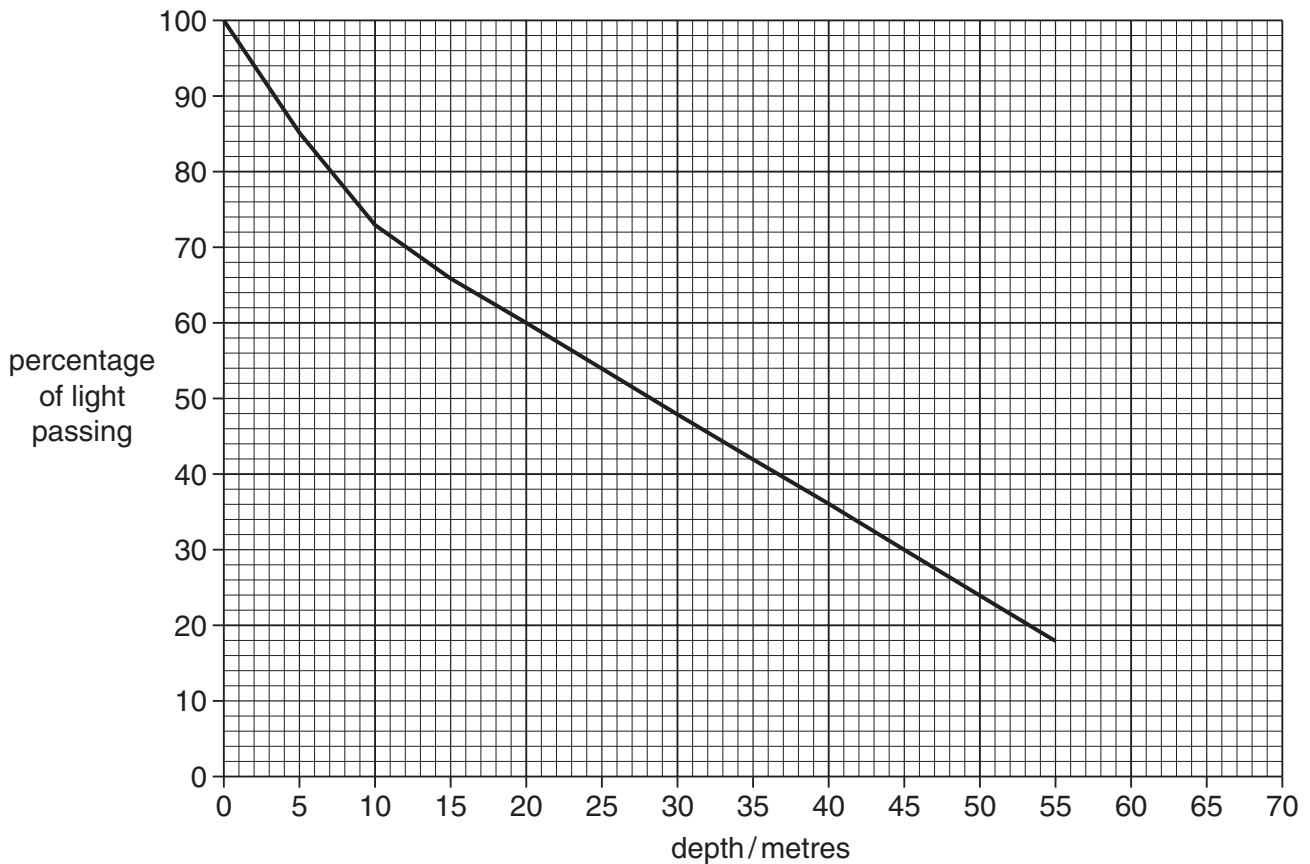

Fig. 2.2

- (i) Using the graph state the percentage of light passing through seawater at a depth of 25 metres.

.....[1]

- (ii) Use the graph to estimate the percentage of light passing through seawater at a depth of 65 metres.

.....[1]

- (iii) Calculate the change in the percentage of light passing through seawater as the depth increases from 0 to 40 metres.

Show your working.

.....[2]

- (iv) State the relationship between depth and the percentage of light passing through seawater.

.....

.....[1]

- (v) As depth increases there is less phytoplankton.

Explain why.

.....

.....

.....

.....[2]

3 (a) Fig. 3.1 shows the consumption of reef fish and the number of tourists.

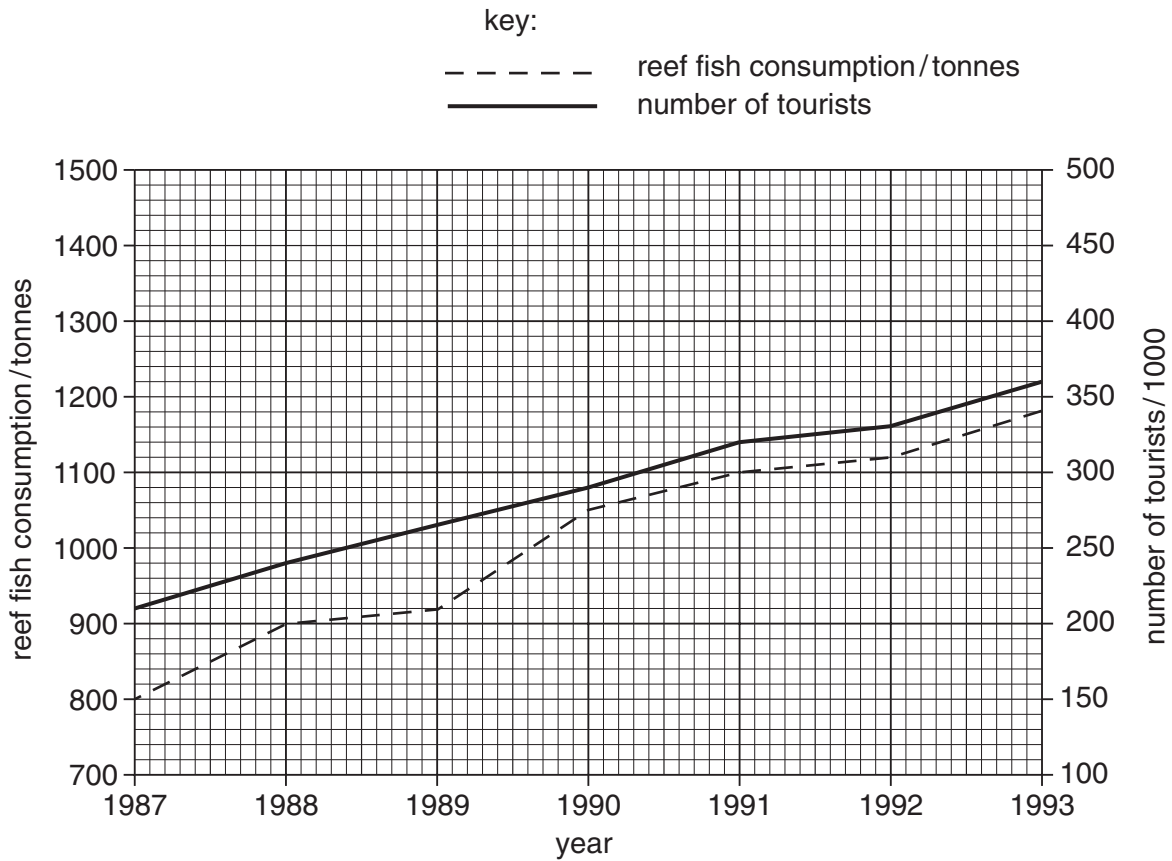

Fig. 3.1

(i) State the number of tourists in 1991.

.....[1]

(ii) Calculate the difference in reef fish consumption between 1988 and 1993.

Show your working.

.....[1]

(iii) State the relationship between the number of tourists and reef fish consumption.

.....
[1]

(b) Describe **two** ways in which the tourist industry in the Maldives is of benefit to fisherman.

*For
Examiner's
Use*

1.....

.....

2.....

.....[2]

4 (a) Fig. 4.1 shows eight animals (not to same scale).

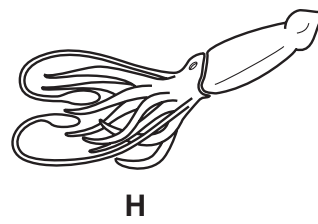
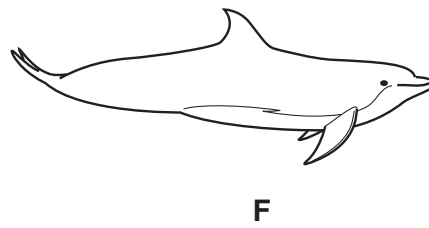
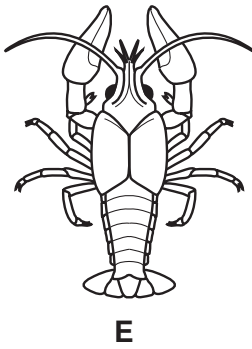
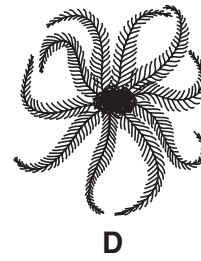
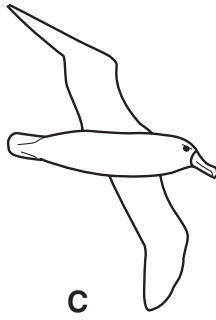
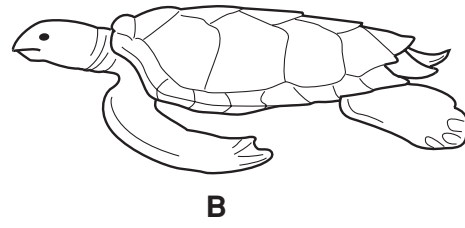
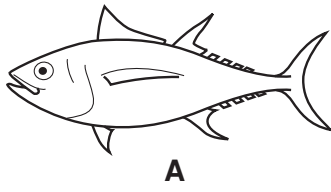

Fig 4.1

Match each of the following with the letters of the animals in Fig 4.1.

For
Examiner's
Use

(i) An animal with feathers.

.....[1]

(ii) An animal with fins and scales.

.....[1]

(iii) A mollusc.

.....[1]

(iv) An aquatic mammal.

.....[1]

(v) A reptile.

.....[1]

(vi) An echinoderm.

.....[1]

(vii) An animal with nematocysts.

.....[1]

(viii) A crustacean.

.....[1]

(b) Table 4.1 shows a classification of a species of tuna (*Katsuwonus pelamis*)
Complete the table by writing the correct words in the boxes.

Table 4.1

Kingdom	Animalia
Phylum	
Class	Osteichthyes
Order	Perciformes
Genus	
Species	pelamis

[2]

5 (a) Table 5.1 shows the amount of tuna caught in the Maldives in 1995, 1996 and 1997.

For
Examiner's
Use

Table 5.1

species	amount of tuna caught/ 1000 tonnes		
	1995	1996	1997
skipjack tuna	71.4	61.9	68.0
yellowfin tuna	13.6	8.0	18.5
other tuna species	8.5	10.1	5.0
total		80.0	91.5

(i) Complete the table by writing in the box the total amount of tuna caught in 1995. [1]

(ii) Calculate the amount of yellowfin tuna as a percentage of the total amount of tuna caught in 1996.

Show your working.

.....[2]

(iii) Name **two** other ways in which the data in Table 5.1 could be presented.

1

2[2]

(b) Place the following organisms into the correct group in Table 5.2.

frigate tuna lobsters marlin sea cucumbers skipjack tuna

Table 5.2

Group	Organism
in-shore species	1
	2
near-shore species	1
	2
off-shore species	1

[5]

- 7 (a) Fig. 7.1 shows the amount of salted and dried skipjack tuna (Lonumas) and canned tuna exported from 1984 to 1990.

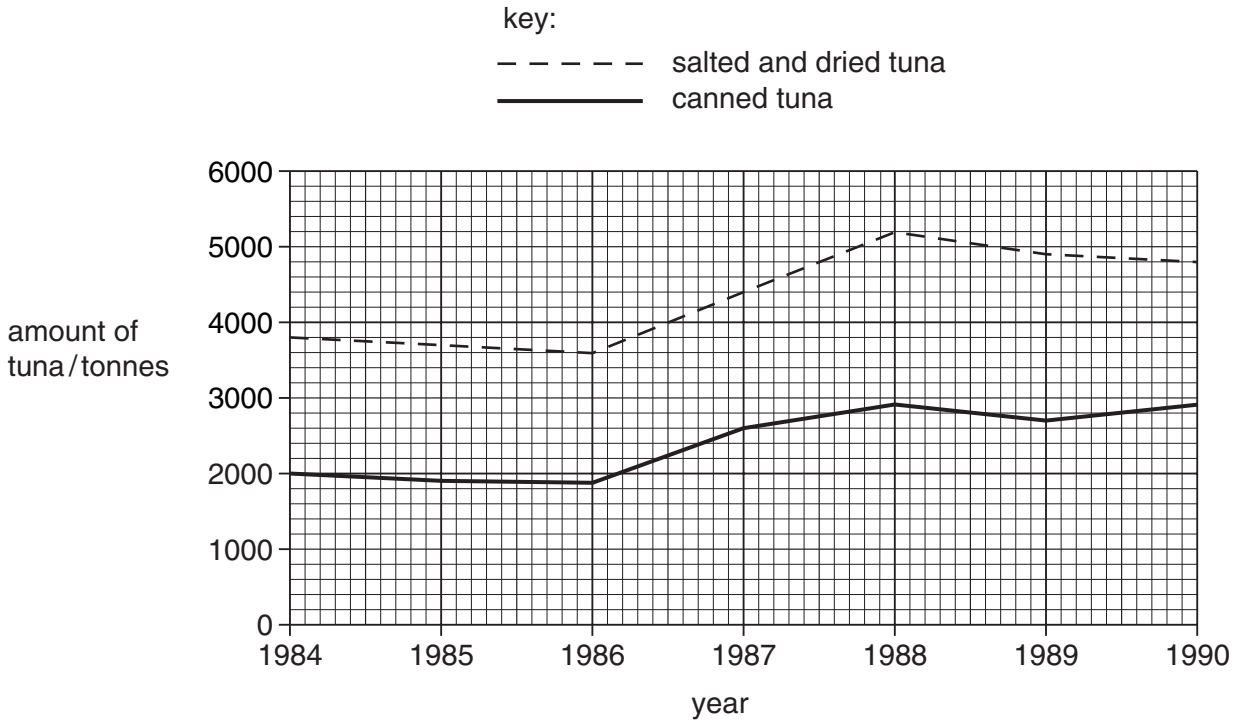

Fig. 7.1

- (i) Describe the changes in the export of salted and dried tuna over the period 1986 to 1990.

.....

 [4]

- (ii) Suggest **two** reasons for the increase in the export of canned tuna between 1986 and 1988.

1

 2
 [2]

- (b) Name a government agency with responsibilities for the export of fish.

..... [1]

8 (a) Fig. 8.1 shows the life cycle of a tuna.

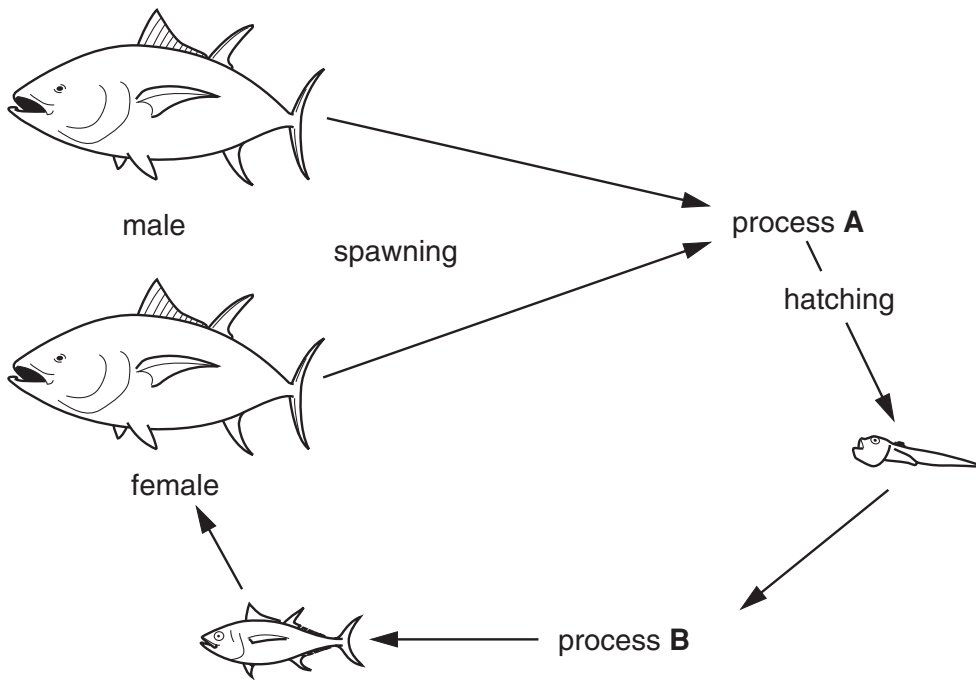

Fig. 8.1

(i) Name processes **A** and **B**.

A.....

B.....[2]

(ii) Name **two** stages in the life cycle of tuna that are part of plankton.

1

2.....[2]

(b) Tuna can produce more than 100 000 eggs when they spawn.
Only about 10 of these survive to become adult tuna.
Suggest **two** reasons why.

1.....

.....

2.....

.....[2]

9 Fig. 9.1 shows three navigational aids (not to the same scale).

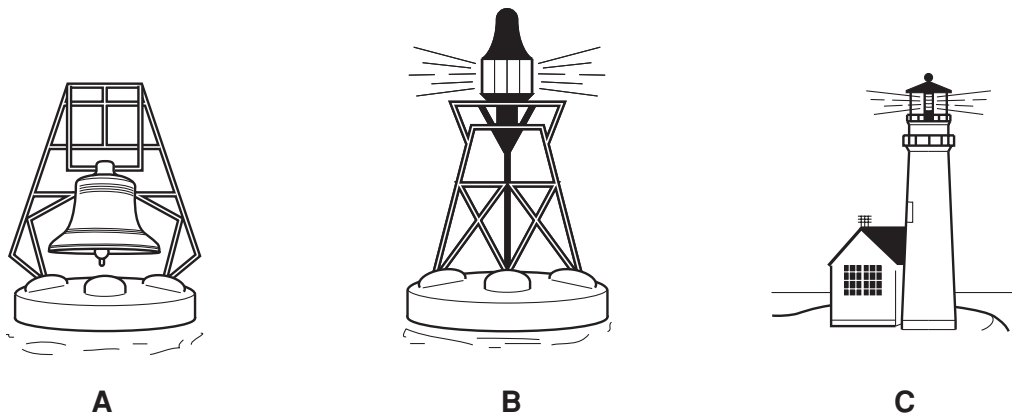

Fig. 9.1

(a) Name each navigational aid.

- A
- B
- C [3]

(b) State the use of each of the following;

(i) An echo sounder

.....
 [1]

(ii) GPS

.....
 [1]

(c) Describe **two** rules which help to prevent ships colliding.

- 1.....

- 2.....
 [2]

(d) State the distress signal used by a ship during the following times.

(i) during the day

.....
.....[1]

(ii) at night

.....
.....[1]

10 (a) Read the passage below about the greenhouse effect.

Complete the passage using words from the list below.

- atmosphere**
 - carbon dioxide**
 - cools**
 - infra-red**
- sulfur dioxide**
 - ultra-violet**
 - warms**

When sunlight travels to the Earth it passes through the

The sunlight the ground which sends out radiation.

Gases in the air, such as traps some of the radiation and this keeps the Earth hotter than normal. [4]

(b) Suggest **two** possible effects global warming may have on the Maldives.

.....
.....[2]

BLANK PAGE

Permission to reproduce items where third-party owned material protected by copyright is included has been sought and cleared where possible. Every reasonable effort has been made by the publisher (UCLES) to trace copyright holders, but if any items requiring clearance have unwittingly been included, the publisher will be pleased to make amends at the earliest possible opportunity.

UCLES is part of the Cambridge Assessment Group. Cambridge Assessment is the brand name of University of Cambridge Local Examinations Syndicate (UCLES), which is itself a department of the University of Cambridge.